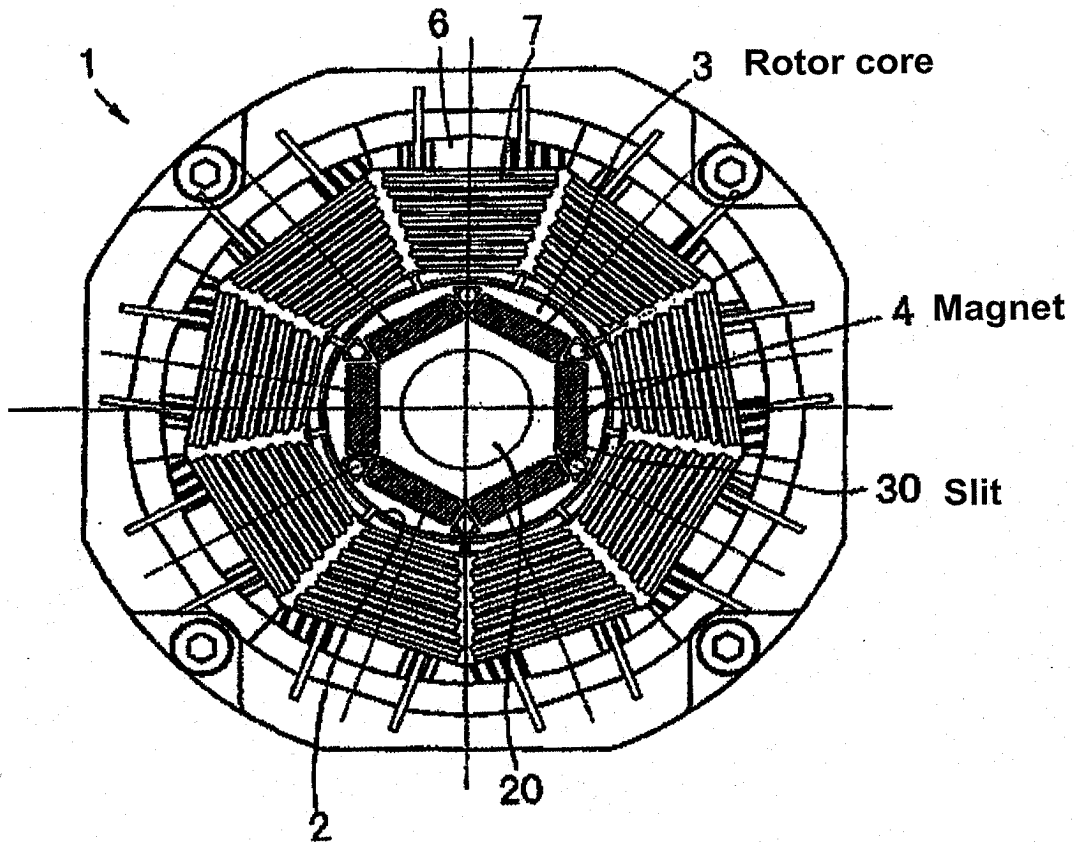

Fig. 1



PAT. 2,659,000

Fig. 2

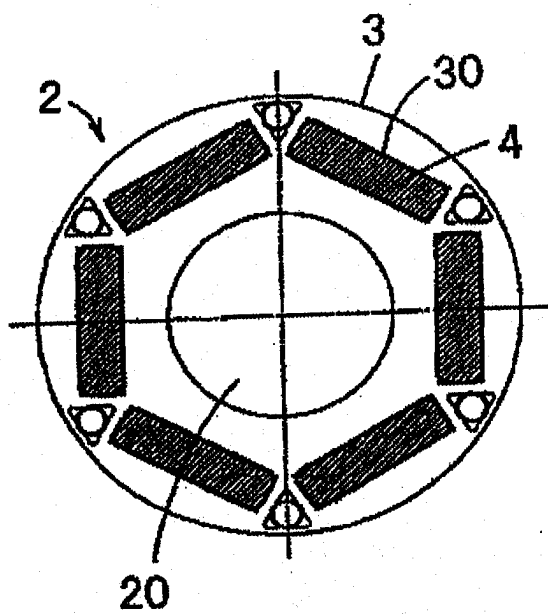

FIG. 2

Fig. 3

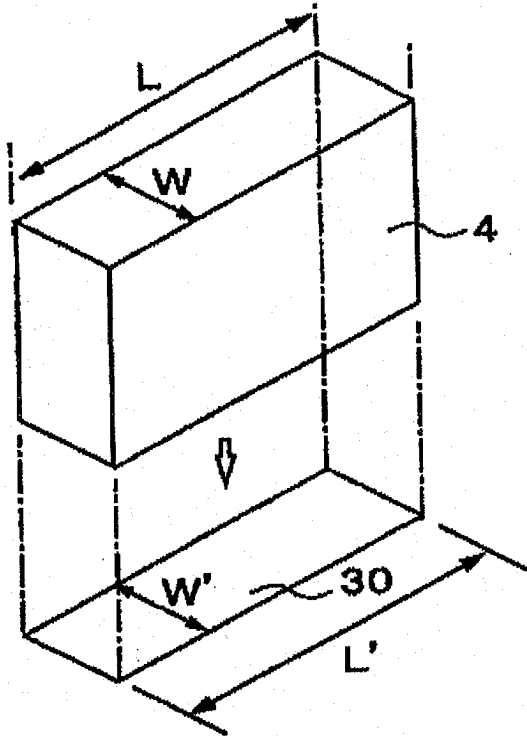

FIG. 3

FIG. 4 (A) (B) (C)

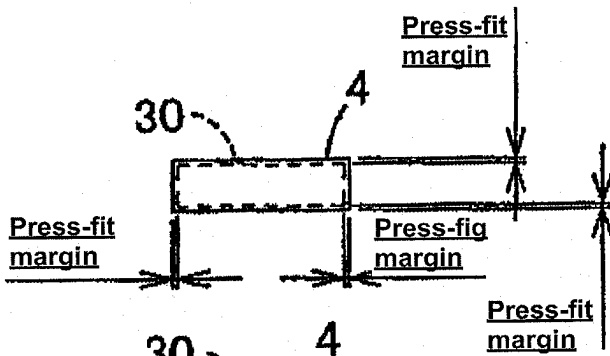

Fig. 4 (A)

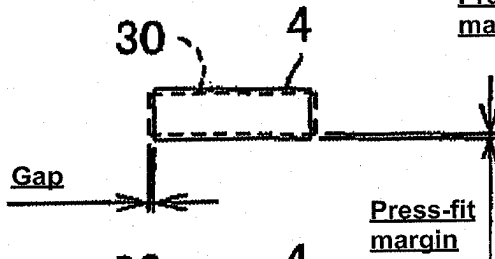

Fig. 4 (B)

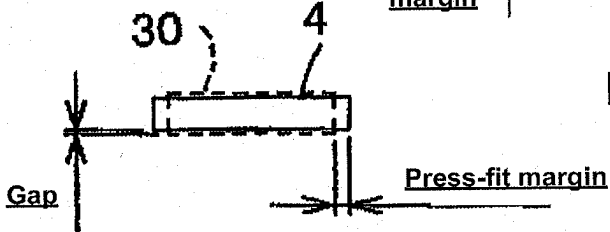
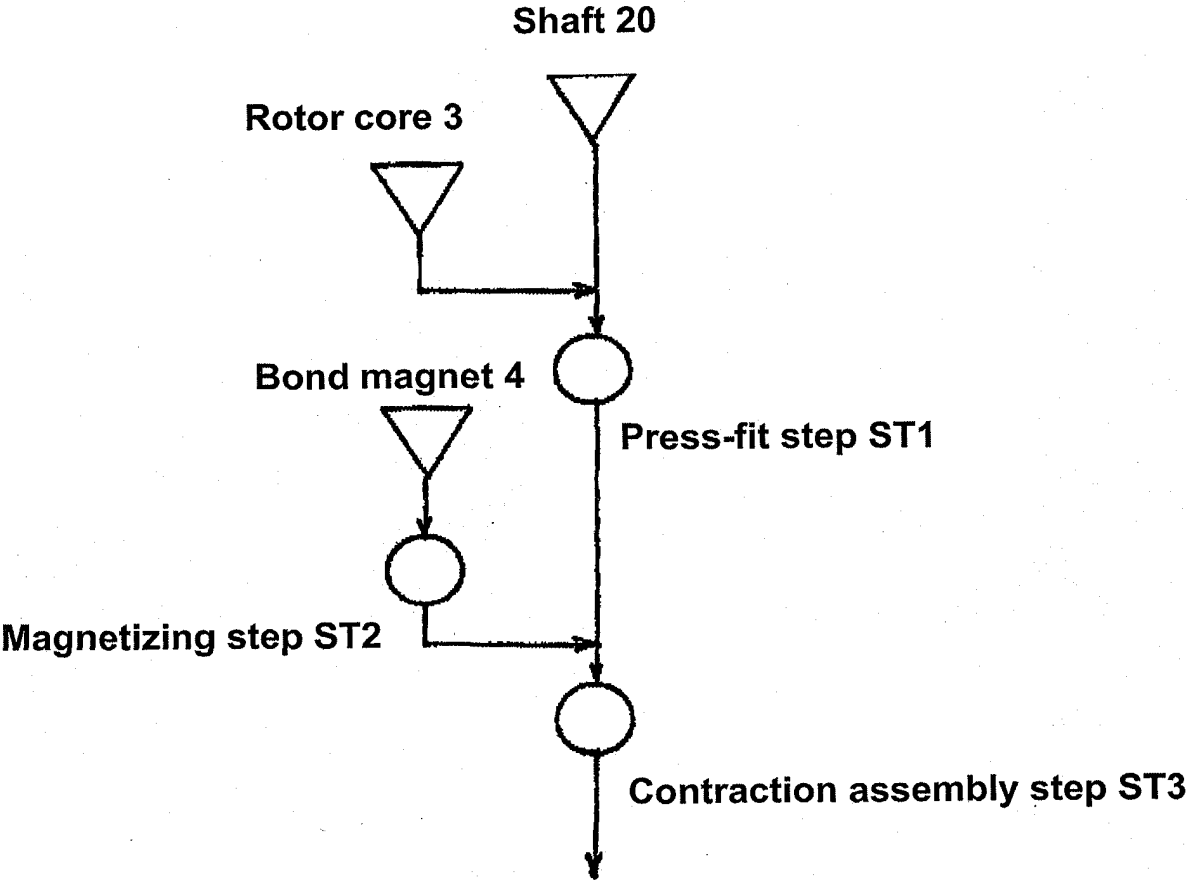

Fig. 4 (C)

Broken line: Cross section of slit  
Solid line: Cross section of magnet

**Fig. 5**



FOR OFFICIAL USE ONLY

Fig. 6

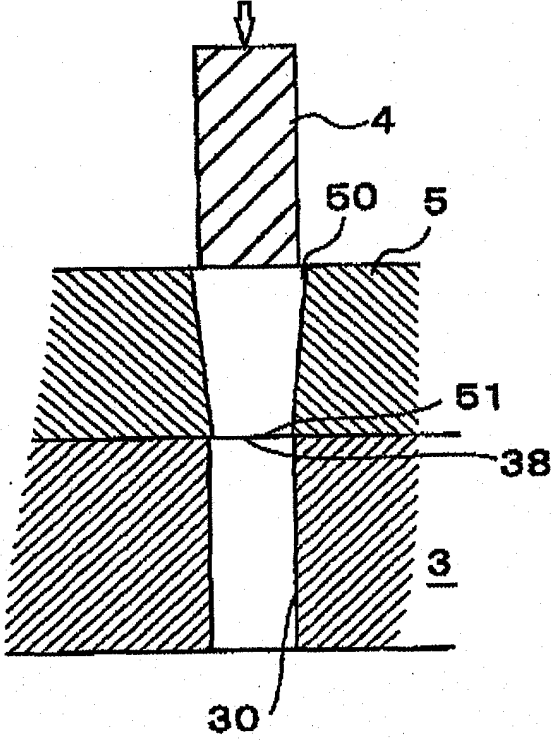

10036090 10001

Fig. 7

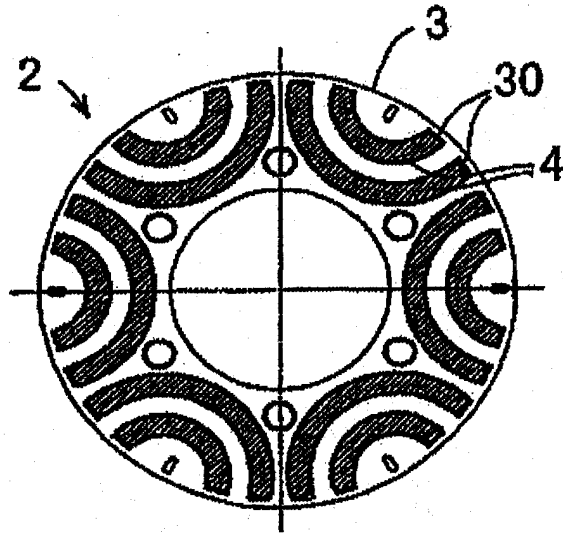
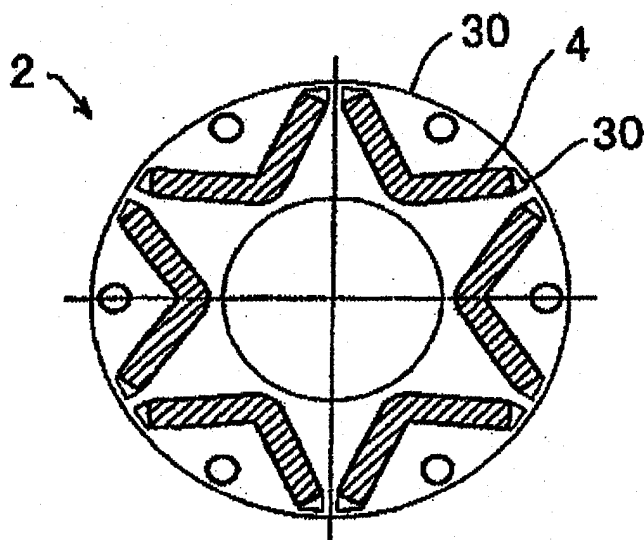

Fig. 8



100360994 J0001 0609007

FIG. 9

Fig. 9

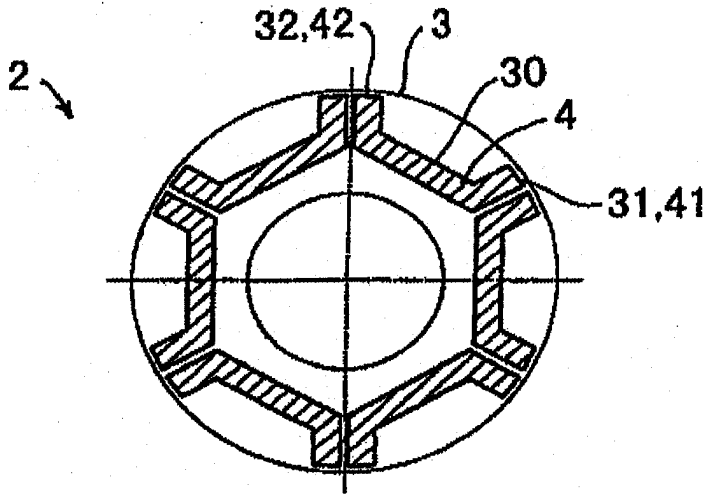

Fig. 10

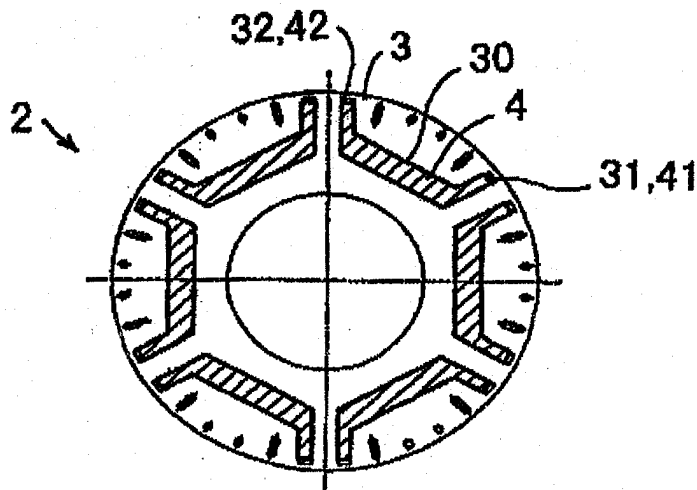



Fig. 11

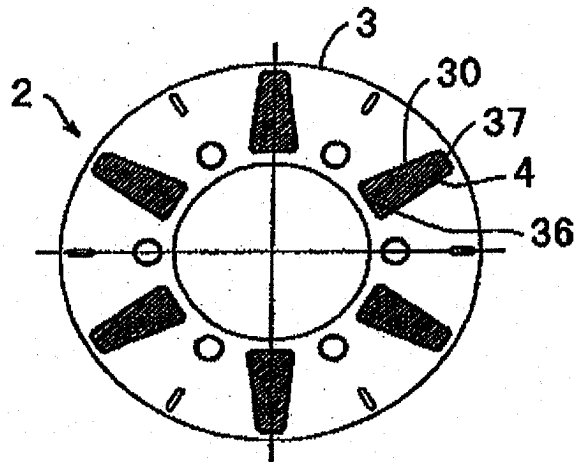

Fig. 12

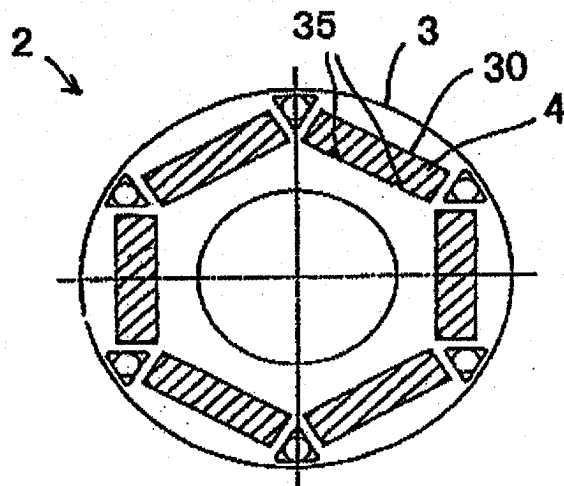

FIG. 13 (A)

Fig. 13 (A)

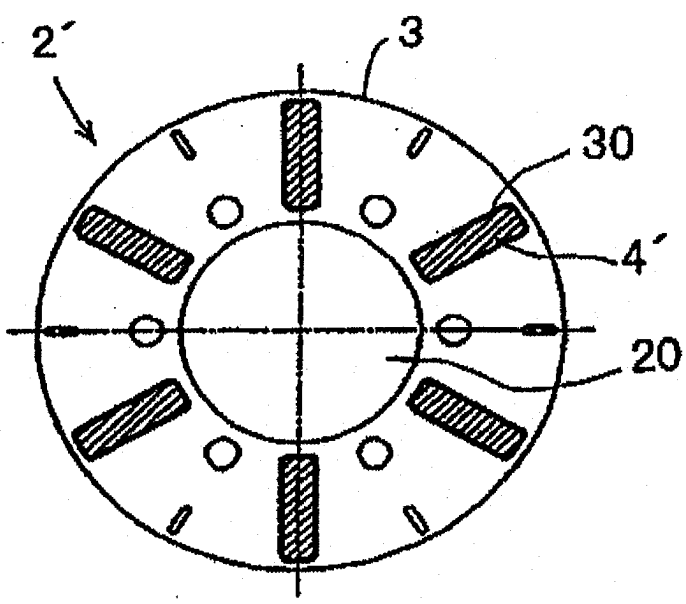

Fig. 13 (B)

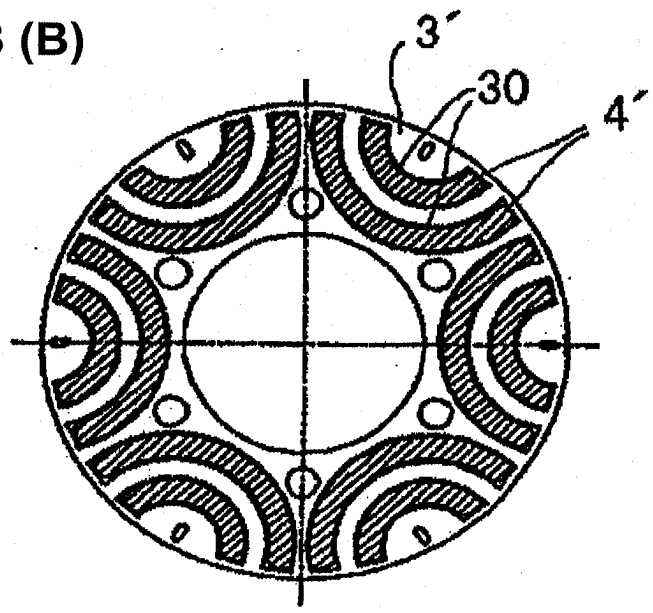

Fig. 14

